

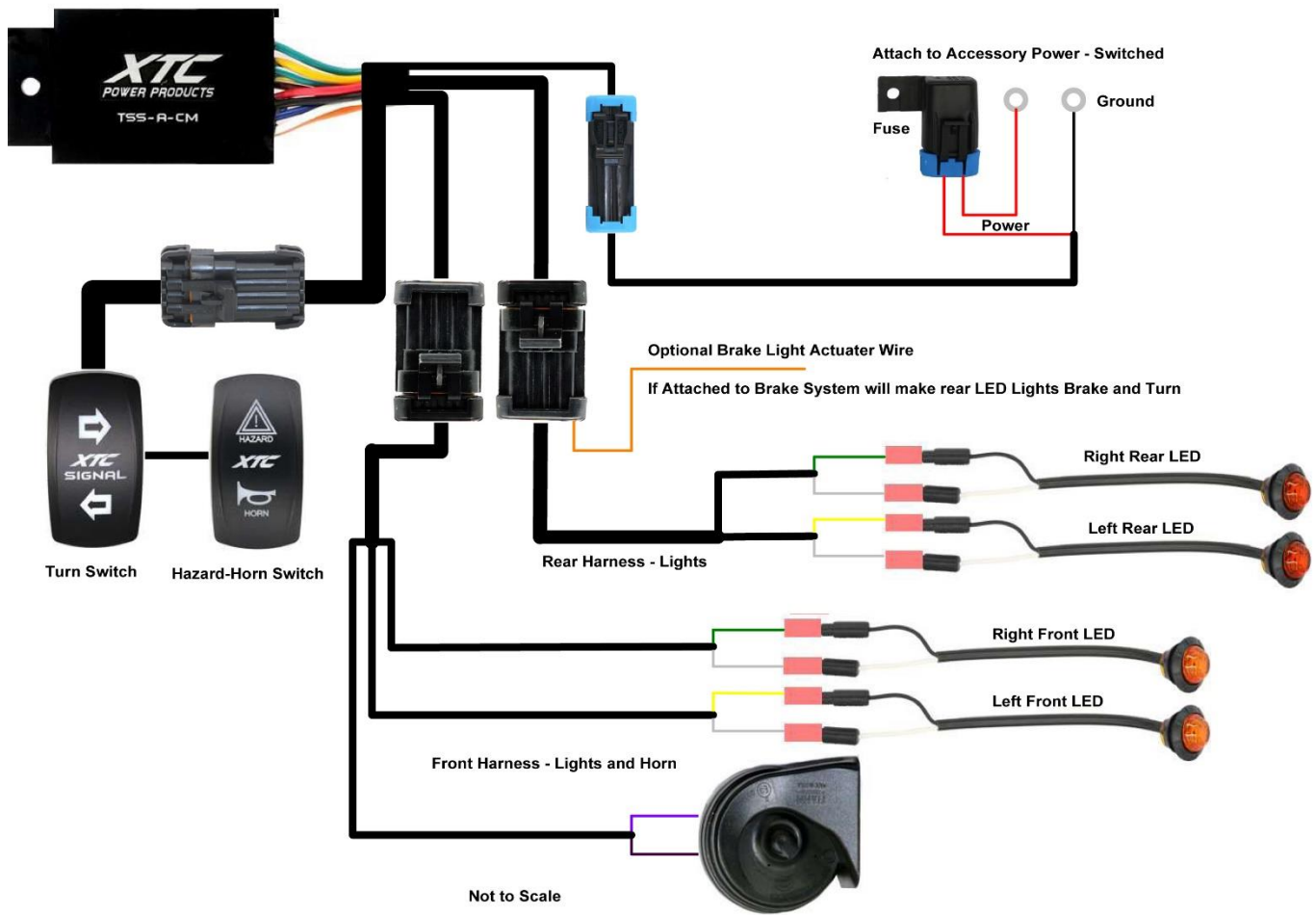

# ATS-UNI UNIVERSAL TURN SIGNAL SYSTEM

Thank you for purchasing XTC Power Products Automatic Self-Canceling Turn Signal System. Our Easy Install Turn Signal System is unique from the other kits on the market. This kit is from our Plug & Play™ product line. With only attaching power, ground and install the four LED Turn Lights.

For more details on installation along with model installation go to [www.xtcinstall.com](http://www.xtcinstall.com)



Please read the instructions fully and familiarize yourself with the components before starting the install.

1. **Mount the Control Module** under the dash or other suitable place using the supplied screw or Cable Tie.

**WARNING! Verify that there is clearance before drilling the holes for the LED's and keep the harness away from any hot or moving parts.**

2. **Install the two front LED lights** - The front LED Turn Indicators can be mounted with the rubber grommet or without. If the grommet is **not** being used drill 5/8" holes. If the grommet is being used drill 3/4" holes. Remove and install the rubber grommet from the LED into the hole if being used. Insert LED into the hole with the Top marking up. NOTE: the TOP marking is on the front of the LED lens.



3. **Run the short front harness** from the front LED lights to the control module and plug into mating connector. The Green wire harness go to the right/passenger side and the yellow wire harness go to the left/driver's side. Both green and yellow wires are positive and go to the black wire on each side, the white wire goes to white. Secure the harness with the provided cable ties. **NOTE: Black wire is positive, and the White is ground, they will not work if reversed.**
4. **Install the Rear LED Lights-** Decide where to mount the two RED LED Turn Indicators, they can be mounted with the rubber grommet or without. If the grommet is **not** being used drill 5/8" holes. If the grommet is being used drill 3/4" holes. Remove and install the rubber grommet from the LED into the hole if being used. Insert LED into the hole with the Top marking up. NOTE: the TOP marking is on the front of the LED lens.

**Optional RZR Old Style Light Modification:** The directions on installing the Rear Turn LED's into a Factory Light can be found at [www.xtcinstall.com](http://www.xtcinstall.com).



Sample: Rear LED Lights installed into an OEM rear Light Housing

5. **Run the Rear Harness** - Start at the right rear of the car and attach the Green and White wires to the right rear LED, the Green gets attached to the black wire and the white to the white wire. Do the same for the left, the Yellow wire gets attached to the black wire and the white wire goes to the white wire. Run the rest of the harness with the four-pin connector up to the control box and plug into the mating connector, make sure to keep the harness away from any hot or moving parts, secure with provided cable ties. **NOTE: Black wire is positive, and the White is ground, they will not work if reversed.**

**WARNING! Verify that there is clearance behind dash for Turn, Hazard and Horn switch's**

6. **Install Turn and Horn/Hazard Switch** – The switches can be mounted different places on the dash, we typically use the driver left side. Using the provided switch template mark the dash, cut out the two rectangles. Push the switch wires through and apply grease (see Below) attach to switch and install in dash.



**Dielectric Grease** - Just like the OEM uses on their switches, we recommend using Dielectric Grease on all switch terminals, this keeps the water out, thereby reducing corrosion and helps increase reliability! Open the grease and put on the switch terminals and the connector terminals on both the Turn and Horn/Hazard switches, the more the better.

7. **Install Horn** – Install the included horn bracket onto the horn. Under the hood mount the horn. Attach the purple and black wire to the horn terminals, position does not matter.

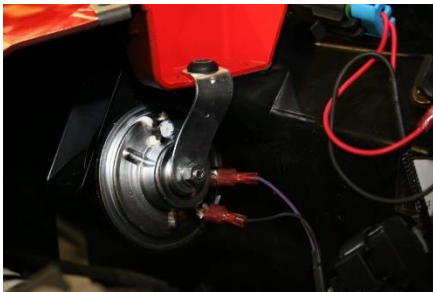

8. **Run the power wire.** Attach the red wire to switched/Keyed 12vdc and the black wire to ground. If there are no keyed factory posts, use the included Posi-Taps. Find 12vdc like the accessory power out or other keyed power. Remove the black cap from one of the Posi-Taps, insert the OEM keyed power wire into the Black Slot and screw the red body back on hand tight only. Take the ATS **RED** Power Wire and cut the Ring Terminal off, strip ¼" of the insulation, push that wire into the other end of the Posi-Tap and screw the end hand tight.

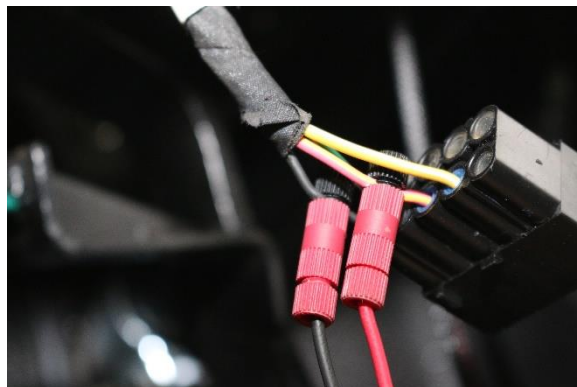
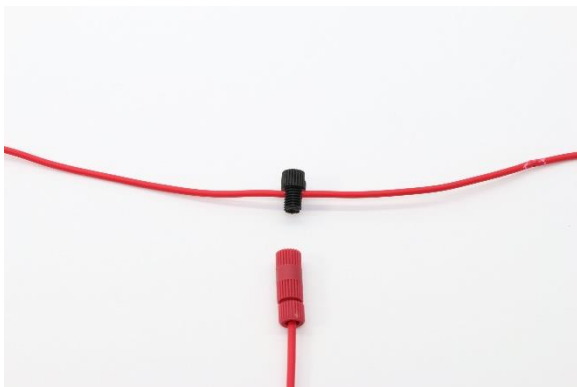

#### Sample

Attach the Black Ring Terminal to Ground or find an OEM ground wire, install the Posi-Tap using the directions above and attach the Black Ground wire to a factory Ground Wire.

9. Verify operation of all lights and secure the harnesses with the provided cable ties.

**Operation:** The System uses momentary switches to activate. Press Right or Left Actuator accordingly. Will cancel as follows.

Press 1 Second for Lane Change, will stay on approx. 8 Seconds / 10 Flashes

Press 2 Seconds for Slowing to Turn Corners, will stay on approx. 20 Seconds / 30 Flashes

Press 5 Seconds for Traffic Lights when stopping and waiting, will stay on approx. 75 Seconds / 110 Flashes

The Systems Automatic Self-Cancelling may be overridden/Shut Off at any time by pushing the activated switch.

Hazard Lights - press to activate and press again to deactivate, it does not self-cancel.

**Optional** - The Tan wire next to the Turn Switch is for an optional Dash Indicator. When the ATS is activated it will flash 12 VDC that can be attached to an Optional Dash Mounted LED Light, it is non-directional, flashes for both right and left signals.

**OPTIONAL: Using the rear turn lights as brake lights** - The orange wire coming out of the rear harness can be used to activate the rear turn lights as brake lights for more visibility. To use, verify with a test light that your car uses positive voltage to the brake lights when pressure is applied to the brake, if you get Positive voltage you may continue. Using the provided Posi-Tap, tap the orange wire into the output side of the brake switch or to a brake light positive wire. Use the Posi-Tap instruction above to attach the Brake Wire.

**For more details on installation go to [www.xtcinstall.com](http://www.xtcinstall.com)**

We can also be reached by email at [support@xtcpowerproducts.com](mailto:support@xtcpowerproducts.com)

XTC Power Products  
A Division of XTC Motorsports LLC  
925 N McQueen RD. #101  
Gilbert AZ 85233  
480-558-8588

[www.xtcpowerproducts.com](http://www.xtcpowerproducts.com)

\*Disclaimer: This kit is intended for off road use only and XTC Motorsports claims no responsibility for its use. It is up to the purchaser to make sure it complies with all Federal, State and Local laws.

R1

Copyright © 2019 XTC MOTORSPORTS LLC, all rights reserved.